

# Installation and Instruction Manual

V510 Series

Pressure Reducing Regulator Valve

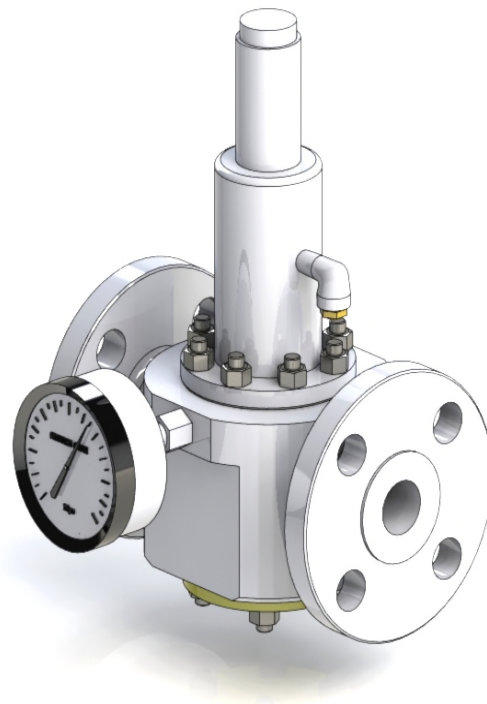

## Table of Contents

### **1. Introduction**

1-1 General

1-2 Personnel qualification

### **2. Product Description**

### **3. Operation**

### **4. Installation**

### **5. Overpressure Protection**

### **6. Startup**

### **7. Adjustment**

### **8. Maintenance**

### **9. Trouble Shooting Guide**

### **10. Specification**

### **11. Part Ordering**

## Terms Concerning Safety

The safety terms Danger, Warning, Caution and Note are used in these instructions to highlight particular dangers and/or to provide additional information on aspects that may not be readily apparent.

**Danger** : indicates that death , severe personal injury and/or substantial property damage will occur if proper precaution are not taken.

**Warning** : indicates that death, severe personal injury and/or substantial property damage can occur if proper precaution are not taken.

**Caution** : indicates that minor personal injury and/or property damage can occur if proper precaution are not taken.

**Note** : indicates and provides additional technical information which may not be obvious, even to qualified personnel.

## 1. Introduction

### 1-1 General

This instruction manual provides installation, startup, and maintenance procedures for the V510 Series Type valves.

### 1-2 Personnel qualification

Transport, installation, commissioning, maintenance or repair must only be performed by trained or instructed personnel.

#### **Warning:**

*In order to ensure successful and safe operation of our valves the entire operation manual must have been read through and understood prior to installation and commissioning. Under certain operating conditions, the use of damaged equipment could cause a degradation of the performance of the system which may lead to personal injury or death. If you have any questions about problems arise, contact UNICON office.*

## 2. Product Description

Pressure Reducing valves automatically reduce a high initial pressure to a lower delivery pressure, and maintain that lower pressure, depending on the specific design selected, within reasonably close limits. Pressure Reducing valves are single seated, self-acting, diaphragm type regulators. V510 series valves offers various modifications of the pressure regulating valve.

## 3. Operation

Pressure Reducing valves maintain a differential pressure between the loading supply pressure and the downstream pressure of the regulator. (Refer to Figure 1, 2)

The design of the valve isolates the diaphragm and pressure response chamber from the main flow stream. The downstream pressure (outlet pressure) is registered under the diaphragm through the sensing orifice. If the downstream pressure increases, pressure under the diaphragm also increases. This force overcomes the spring compression and loading supply pressure, allowing the stem to rise.

The valve plug spring forces it to close the valve. Flow through the valve is reduced so that downstream pressure returns to the desired differential level. When the downstream pressure decreases, the opposite action takes place. Pressure under the diaphragm decreases. The valve stem pushes the valve plug downward, opening the flow stream and increasing the flow through the regulator. Downstream pressure rises back to the desired differential level.

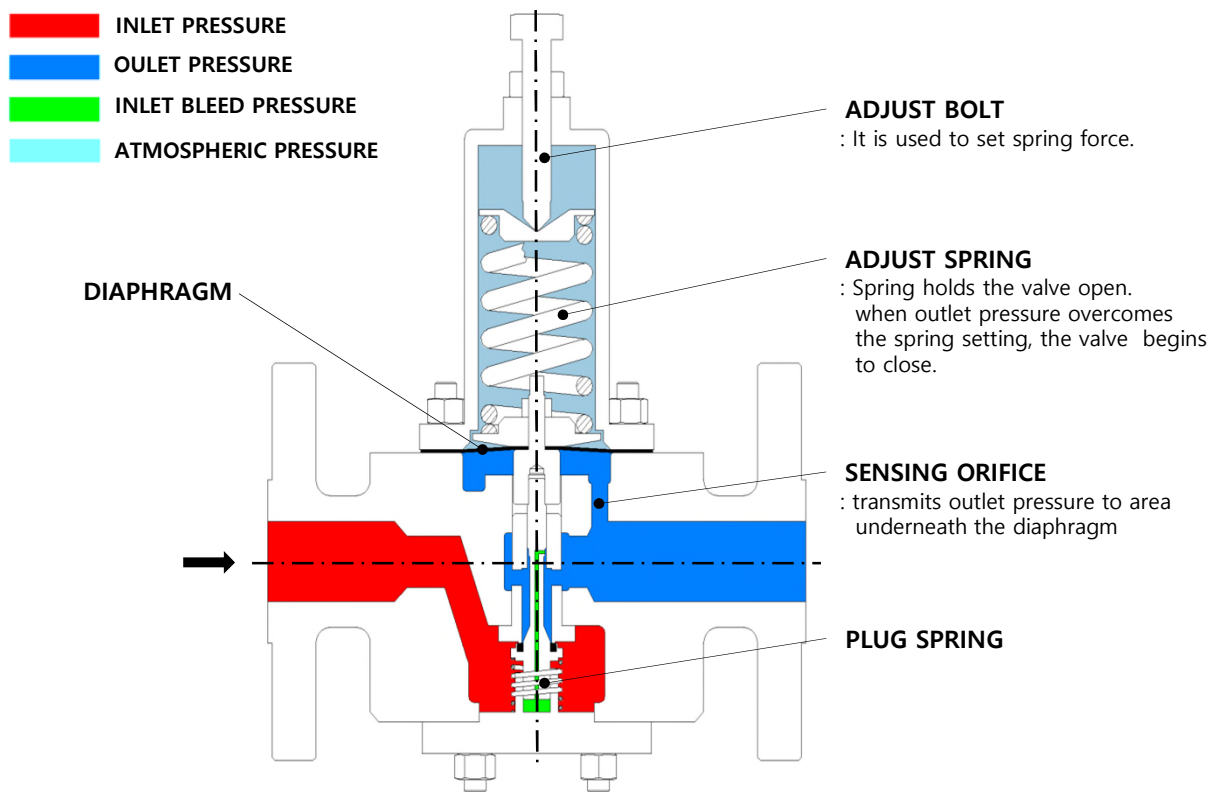

Figure 1. Operational Schematic (Valve Close)

## 4. Installation

Clean out all pipelines before installation of the regulator and check to be sure the regulator has not been damaged or collected foreign material during shipping. Apply pipe compound to the external pipe threads and install the regulator in any position desired, but be sure flow through the body is in the direction indicated by the arrow cast on the body.

### **Warning:**

*Only qualified personnel should install or service a valve. valve should be installed, operated, and maintained in accordance with international and applicable codes and regulations. If a leak develops in the system, it indicates that service is required. Failure to take the valve out of service immediately may create a hazardous condition. Personal injury, equipment damage, or leakage due to escaping fluid or bursting of pressure-containing parts may result if this valve is over pressured or is installed where service conditions could exceed the limits given in the Specifications section, or where conditions exceed any ratings of the adjacent piping or piping connections. Additionally, physical damage to the valve could result in personal injury and property damage due to escaping fluid. To avoid such injury and damage, install the valve in a safe location.*

## 5. Overpressure Protection

The Pressure Reducing Regulator Valve Types have an outlet pressure rating lower than the inlet pressure rating. The recommended set pressure limitations are stamped on the nameplate. Some type of over pressure protection is needed if the actual inlet pressure exceeds the maximum operating outlet pressure rating. Overpressure protection should also be provided if the regulator inlet pressure is greater than the safe working pressure of downstream equipment.

Some type of external overpressure protection should be provided if inlet pressure will be high enough to damage downstream equipment.

Common methods of external overpressure protection include relief valves, monitoring regulators, shutoff devices, and series regulation.

Regulator operation below the maximum pressure limitations does not preclude the possibility of damage from external sources or from debris in the pipeline.

If the regulator is exposed to an overpressure condition, it should be inspected for any damage that may have occurred.

## 6. Start up

The valve is set at the factory for the set pressure specified on the order, so no initial adjustment should be required to give the desired results. With proper installation completed and valves properly adjusted, slowly open the upstream and downstream shutoff valves.

## 7. Adjustment

The factory setting of the regulator can be varied within the pressure adjustable range. To change the outlet pressure, loosen the locknut and turn the adjusting bolt clockwise to increase outlet pressure, or counterclockwise to decrease it. (Refer to figure 3, 4) Monitor the outlet pressure with a test gauge during the adjustment. Tighten the locknut to maintain the desired setting.

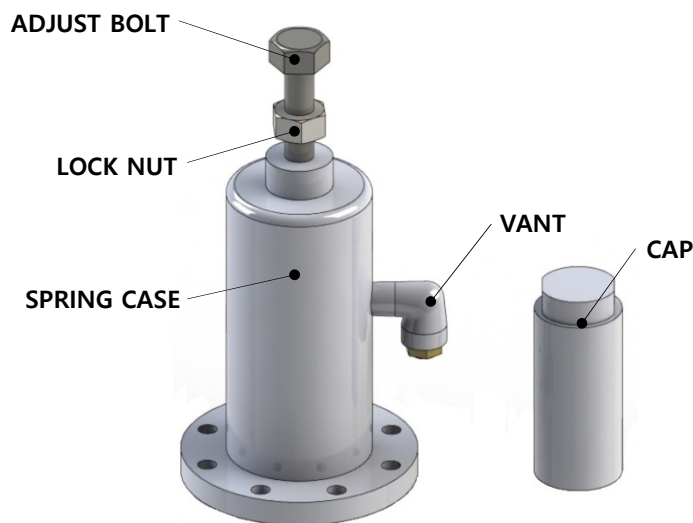

Figure 2. Adjustment

## 8. Maintenance

### Warning:

*To avoid personal injury, property damage, or equipment damage caused by sudden release of pressure or explosion of accumulated gas, do not attempt any maintenance or disassembly without first isolating the regulator from system pressure and relieving all internal pressure from the valve.*

Due to normal wear that may occur, parts must be periodically inspected and replaced if necessary. The frequency of inspection and replacement depends upon the severity of service conditions or the requirements of state and federal laws.

This section includes instructions for disassembly and replacement of parts. All key numbers refer to Figure 4.

1. If diaphragm damage is suspected, or to inspect the diaphragm or other internal parts, loosen the locknut and turn the adjust bolt to remove all spring compression.
2. Remove the stud, nut from the spring case. Lift the entire spring case off of the body. Remove the upper spring seat and adjust spring.
3. Unscrew the diaphragm connector nut and remove lower spring seat.

4. Remove the diaphragm and examine for damage. Replace if damage is verified.
5. If it appears that the valve does not shut off tightly, the orifice cage and valve plug may be worn or damaged.
6. Unscrew the bottom flange from the body. The valve plug spring will normally come out of the body along with the bottom flange.
7. After separating the connector and valve plug, inspect the seating surface of the valve plug, make sure that the elastomer or polished metal surface of the valve plug is not damaged. Replace if damage is verified.
8. Inspect the seating edge of the orifice cage. If damage is verified. unscrew the orifice cage from the body and replace it with a new part.
9. If no further maintenance is required, reassemble the valve in the reverse of the above steps.

## 9. Trouble shooting Guide

TROUBLE	SYMPTOM POSSIBLE CAUSE	CORRECTIVE ACTION
The desired pressure cannot be obtained.	The inlet pressure is too low or high.	Change the pressure to the appropriate level.
	The sensing port of the outlet pressure is clogged with foreign matter.	Disassemble and clean the sensing port.
	The valve size is smaller than what is required.	Change the valve size to the appropriate one
	The adjustment is not appropriate.	Readjust according to the adjustment procedure.
	The inlet strainer is clogged by foreign substance.	Disassemble and clean the strainer
	The pressure gauge is not functioning properly.	Replace the pressure gauge.
The outlet pressure rises higher than the specified pressure.	The valve or valve seat is contaminated by foreign substance.	Disassemble and clean the valve or the seat.
	The by-pass valve is leaking.	Repair or replace the by-pass valve
Abnormal noise is heard.	The reducing ratio is excessively large.	Reduce pressure by staging with second PRV.
	There is a fast closing valve near the PRV.	Provide as long a distance as possible between the two valves

**Table 1. V510Series Pressure Reducing Valve Trouble shooting**

## 10. Specification

**Maximum Operating Inlet Pressure**  
15BarG

**Control Pressure Ranges**  
0.1BarG ~ 3.5BarG

**Maximum Operating Outlet Pressure**  
7BarG

**Operating Temperature Range**  
0°C ~ 100 °C

**Pressure Registration**  
Internal

**Main Valve Flow Characteristic**  
Linear

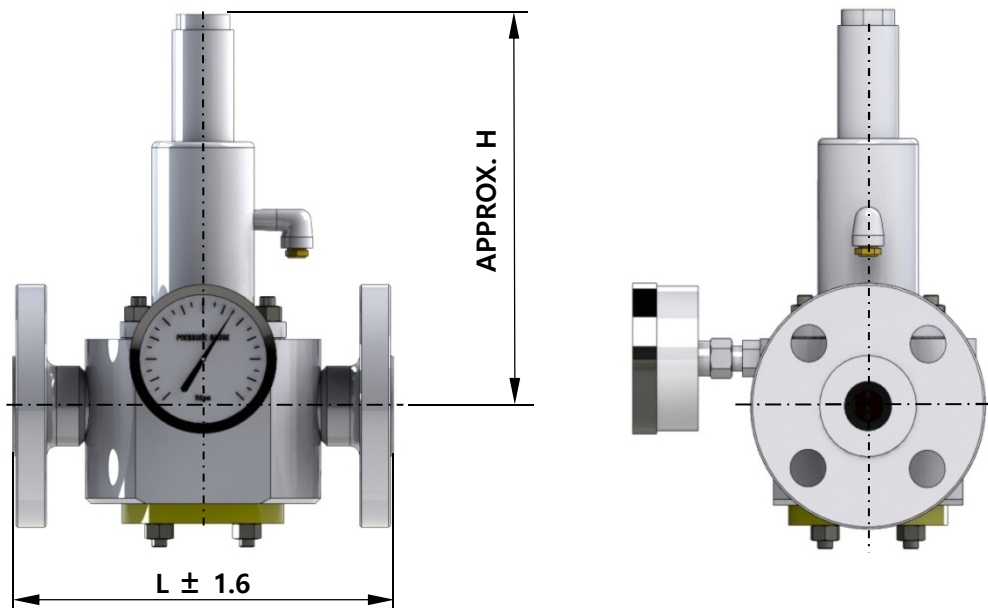

**Figure 3. Dimensional Diagrams**

Valve Tag No.	1021-PCV-0126	1321-PCV-0001	1021-PCV-0136 A/B
Valve Size (300lbs)	1"(25A)	1"(25A)	2" (50A)
Set Pressure (Bar)	0.3	3.5	0.5
Control Pressure Range (Bar)	0.1 ~ 0.6	2 ~ 5	0.3 ~ 0.8
Adjustable Spring Wire Diameter, mm (inch)	4 (0.16)	6 (0.24)	4 (0.16)
Adjustable Spring Free Length, mm (inch)	100 (3.94)	90 (3.54)	100 (3.94)
L (mm)	197	197	267
H (mm)	205	190	215
Weight	APPROX. 40Kg	APPROX. 40Kg	APPROX. 45Kg

**Table 2. V510Series Pressure Reducing Regulator Valve Specification**



## 11. Part Ordering

Key	Description	Material
1	Body	A105
2	Body Flange	A105
3	Plug	316L SS or 316L SS + EPDM
4	Cage	316L SS
5	Stud & Nut	A193 B7 / A194 2H
6	Stud & Nut	A193 B7 / A194 2H
7	Dia. Connector	304 SS
8	Diaphragm	EPDM
9	Plug Spring	STAINLESS STEEL
10	Adjust Spring	SPRING STEEL
11	Upper Spring Seat	304 SS
12	Lower Spring Seat	304 SS
13	Adjust Bolt	304 SS
14	Lock Nut	304 SS
15	Spring Case	304 SS
16	Cap	304 SS
17	O-Ring	NBR, EPDM/FDA, KFM, FFKM
18	O-Ring	NBR, EPDM/FDA, KFM, FFKM
19	O-Ring	NBR, EPDM/FDA, KFM, FFKM

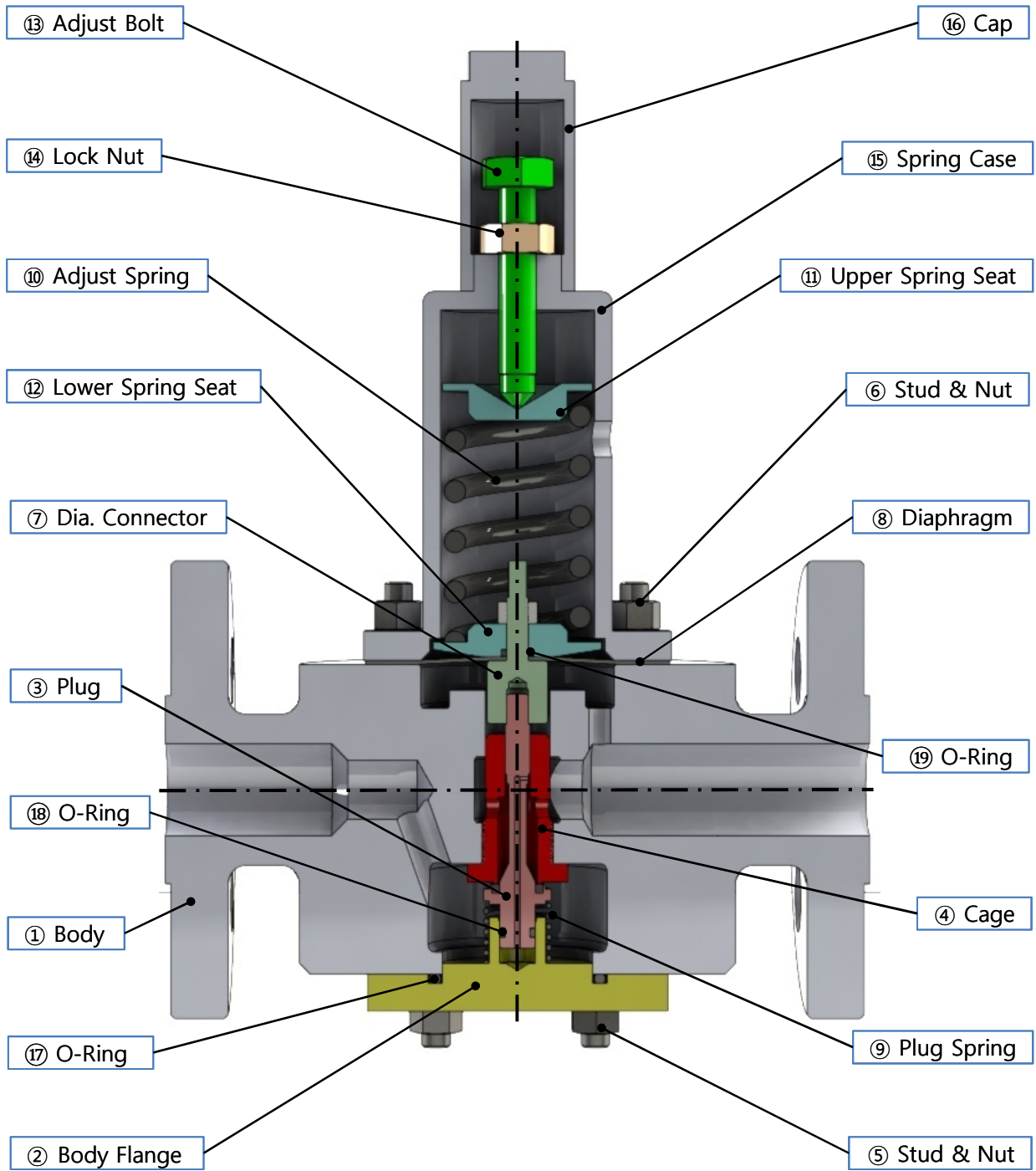
**Figure 4. Assembly Drawing (Sectional)**

Figure 4-1. Assembly Drawing

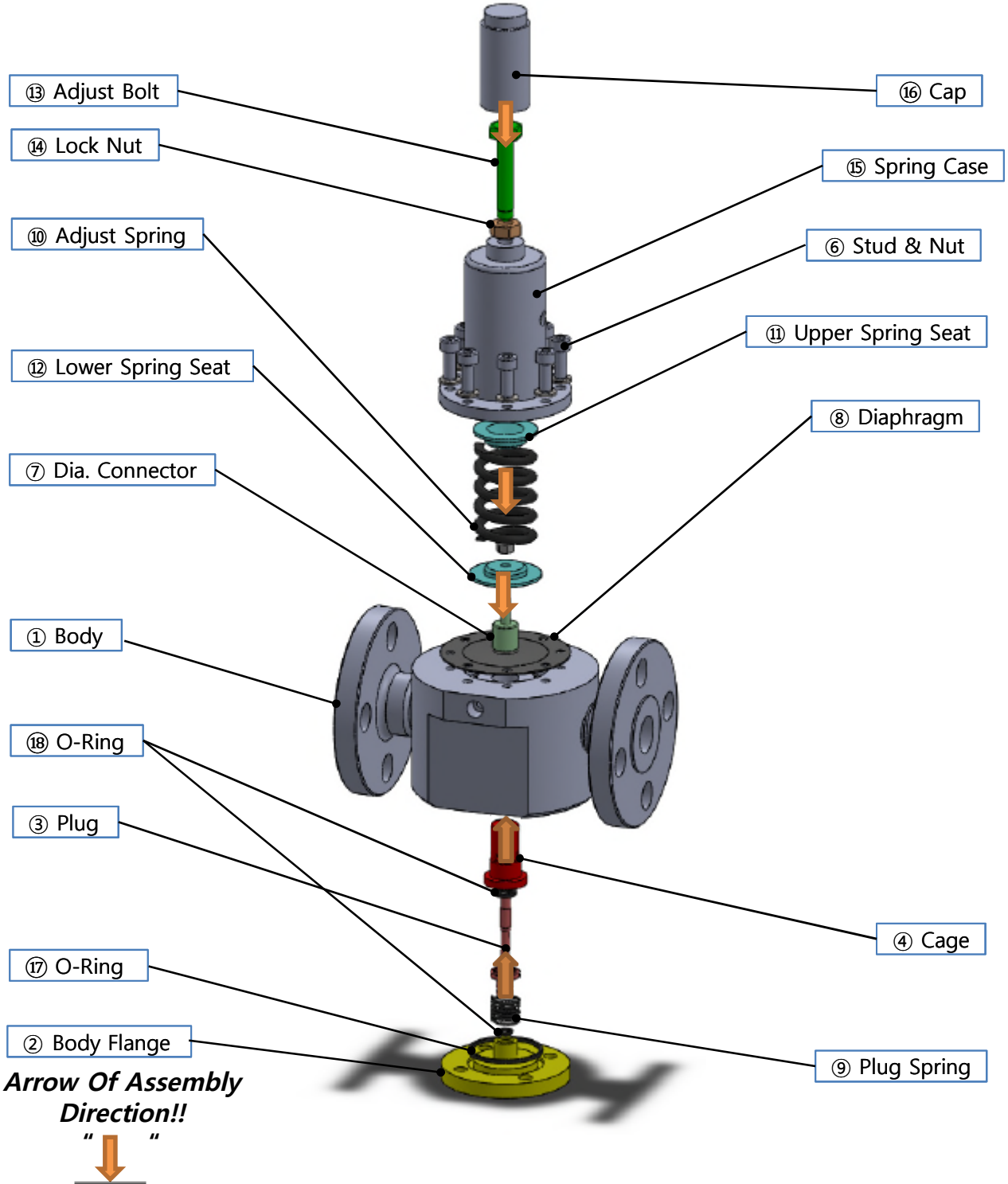

Assembly Part Name	Order
Figure.4	① → ⑦ → ⑧ → ⑫ → ⑩ → ⑪ → ⑮ → ⑥ → ⑭ → ⑬ → ⑱ ① → ④ → ⑱ → ③ → ⑨ → ⑱ → ⑰ → ②